

1

2

3

4

A

B

C

D

E

F

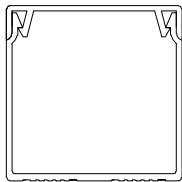
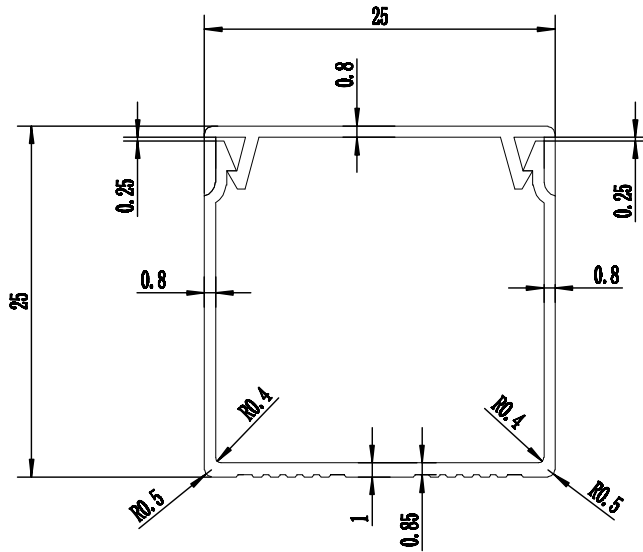
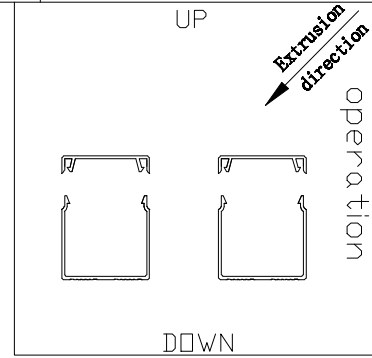

1:1

I CONFIRM, THAT THIS PROFILE SECTION IS OK. I ALSO CHECKED THIS PROFILE-SECTION WITH MY HARDWARE AND WITH MY SEALS AND GASKETS-MANUFACTURER. I CONFIRM, THAT THIS PROFILE SECTION IS OK FOR THE HARDWARE THAT I WANT TO USE.

DATE, SIGNATURE: _____

1. VISIBLE SIDE THICKNESS: $0.8 \pm 0.2\text{mm}$.
NON-VISIBLE SIDE THICKNESS: $0.8 \pm 0.2\text{mm}$.
2. OUTLINE TOLERANCE: $\pm 0.5\text{mm}$.

AONA EXTRUSION TOOLING

drawing



<https://www.aonatooling.com>

1

2

3

4

由 Autodesk 教育版产品制作

由 Autodesk 教育版产品制作