

1

2

3

4

A

A

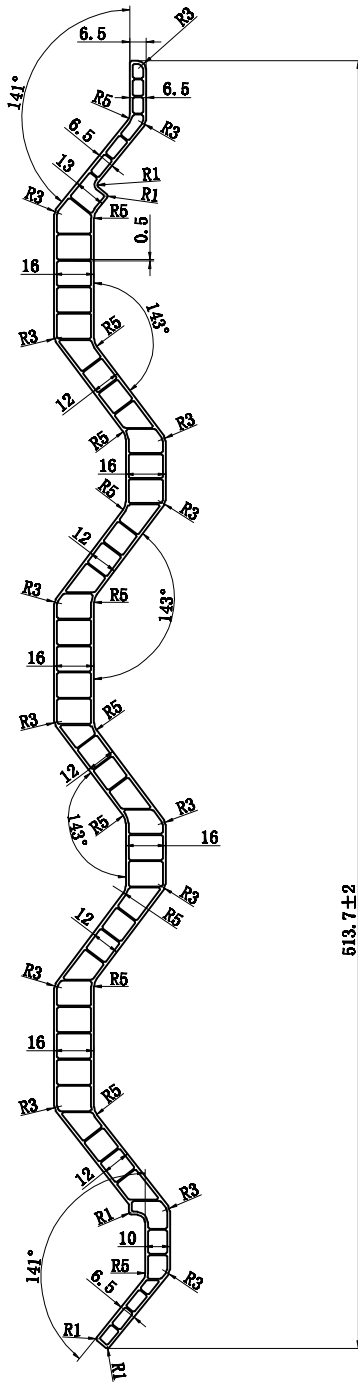

D

D

E

E

I CONFIRM, THAT THIS PROFILE SECTION IS OK. I ALSO CHECKED THIS PROFILE-SECTION WITH MY HARDWARE AND WITH MY SEALS AND GASKETS-MANUFACTURER. I CONFIRM, THAT THIS PROFILE SECTION IS OK FOR THE HARDWARE THAT I WANT TO USE.

DATE, SIGNATURE: \_\_\_\_\_

- 1. VISIBLE SIDE THICKNESS:  $1.2 \pm 0.2\text{mm}$ .  
INNER SIDE LAYER:  $0.5 \pm 0.2\text{mm}$ .
- 2. OUTLINE TOLERANCE:  $\pm 0.5\text{mm}$ .
- 3. CROSS SECTION SIZE:  $1693.7\text{mm}^2$ .

AONA EXTRUSION TOOLING

drawing

F

F

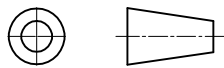

<httpS://www.aonatooling.com>

1

2

3

4