

1

2

3

4

A

A

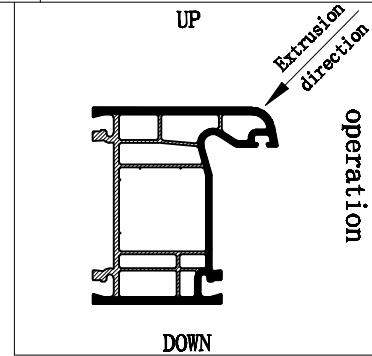

B

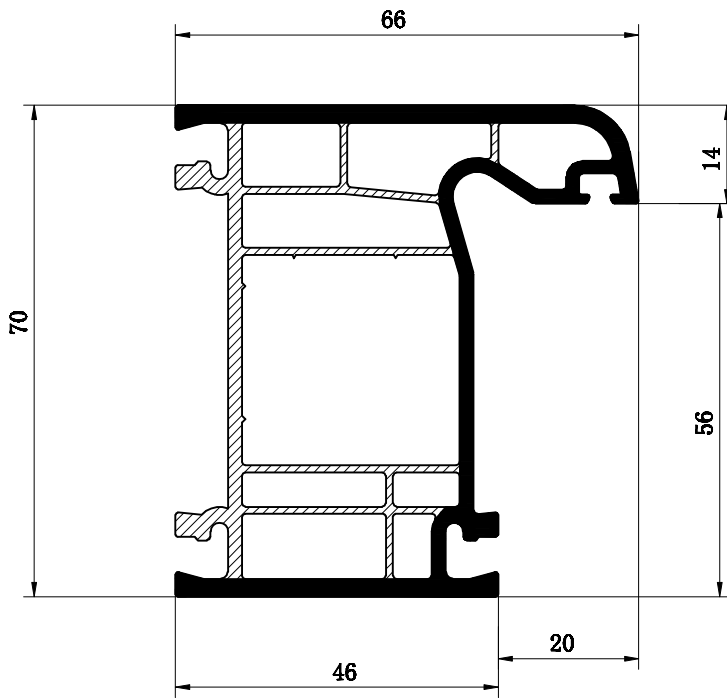

C

C

D

D

由 Autodesk 教育版产品制作

由 Autodesk 教育版产品制作

E

E

I CONFIRM, THAT THIS PROFILE SECTION IS OK. I ALSO CHECKED THIS PROFILE-SECTION WITH MY HARDWARE AND WITH MY SEALS AND GASKETS-MANUFACTURER. I CONFIRM, THAT THIS PROFILE SECTION IS OK FOR THE HARDWARE THAT I WANT TO USE.

DATE, SIGNATURE: _____

1. VISIBLE SIDE THICKNESS: $3.0 \pm 0.2\text{mm}$.
NON-VISIBLE SIDE THICKNESS: $2.5 \pm 0.2\text{mm}$.
INNER SIDE LAYER: $1.0 \pm 0.2\text{mm}$.
2. OUTLINE TOLERANCE: $\pm 0.5\text{mm}$.
3. CROSS SECTION SIZE: mm^2 .
4. THEORETICAL METER WEIGHT: kg/m
5. 10KG CACO3 IS ADDED TO 100KG PVC DURING PROFILE PRODUCTION

AONA EXTRUSION TOOLING

70 frame

F

F



<https://www.aonatooring.com>

1

2

3

4